

**RSH/RSV Series - Physical Data**

<b>Model Series</b>	007	009	012	018	024	030	036	042	048	060	070
Nominal Cooling (Ton) <sup>1</sup>	0.5	0.75	1.0	1.5	2.0	2.5	3	3.5	4	5	6
<b>Compressor-Type</b>	Rotary			Reciprocating				Scroll			
<b>Air Coil-Type</b>	Enhanced Copper tubes, Enhanced Aluminum Fins										
Face Area(sq ft)	1.17	1.17	1.33	2.56	2.88	2.88	3.47	4.44	4.44	6.11	6.11
Rows/FPI	3/13	3/13	3/15	3/15	3/15	3/15	3/15	3/15	3/15	3/15	3/15
<b>Water Coil-Type</b>	Enhanced Surface Co-Axial										
Water Connection (FPT)	1/2"	1/2"	1/2"	3/4"	3/4"	3/4"	3/4"	3/4"	3/4"	1"	1"
Drain Connection (FPT)	3/4"										
<b>Standard Blower / Motor</b>	DWDI Forward-Curved Centrifugal / PSC Direct-Drive										
Diameter x Width (in)	6x5	6x5	6x6	9x7	9x7	10x7T	10x7T	11x8T	11x8T	11x10T	11x10T
Motor HP	0.10/3	0.10/3	0.13/3	0.17/3	0.25/3	0.33/3	0.50/3	0.50/3	0.75/3	1.0/3	1.0/3
<b>RSH Filter</b> Quantity-Size(in)	1-12x16	1-12x16	1-12x20	1-18x24	1-18x24	1-18x24	2-14x20	2-18x20	2-18x20	2-22x22	2-22x22
<b>RSV Filter</b> Quantity-Size(in)	1-12x20	1-12x20	1-12x20	1-18x24	1-20x25	1-20x25	1-24x24	2-14x25	2-14x25	2-16x30	2-16x30
<b>RSH Cabinet Weight (lb)</b>	130	135	145	195	210	215	240	310	320	370	385
<b>RSV Cabinet Weight (lb)</b>	120	125	135	185	200	210	230	305	315	375	390

## NOTE:

1) Nominal Capacity calculated in accordance with AHRI / ISO Standard 13256-1 for Water Loop Application

## OPERATING LIMITS\*

	COOLING	HEATING
Min. Entering Water	30°F	20°F
Max. Entering Water	110°F	90°F

\*Units are capable of operation with an entering fluid temperature range of 20°F to 110°F

\*Low-Temp Option is recommended for water temperatures below 40°F

*Johnson Controls maintains a continuous product improvement policy; therefore specifications are subject to change without notice.*

BY JOHNSON CONTROLS

## DESCRIPTION

PHYSICAL DATA  
R-410A  
RSH & RSV SERIES  
WATER SOURCE HEAT PUMP

Form SK145.16-PA12 (1209)

DATE:

December 2009

**PERFORMANCE DATA - AHRI/ISO 13256-1 WATER LOOP CONDITIONS\***

Unit Model	Flow Rate (USGPM)	Air Flow (SCFM)	Cooling Capacity (Btuh)	EER	Heating Capacity (Btuh)	COP
007	1.8	260	6,800	12.5	8,700	4.5
009	2.4	320	8,900	12.4	11,600	4.4
012	3.0	425	12,400	12.2	15,600	4.2
018	4.8	640	19,100	13.2	23,400	4.5
024	6.0	800	24,600	13.5	29,300	4.4
030	7.8	1000	29,800	13.3	35,300	4.5
036	9.0	1200	36,200	13.0	45,100	4.6
042	10.4	1400	42,700	12.7	50,600	4.4
048	12.0	1600	48,300	13.1	57,200	4.5
060	15.0	2000	60,500	13.4	70,800	4.6
070	17.5	2200	67,700	12.9	79,500	4.3

\*Water Loop capacities are rated at 86°F EWT Cooling, 68°F EWT Heating.

**PERFORMANCE DATA - AHRI/ISO 13256-1 GROUND WATER CONDITIONS\***

Unit Model	Flow Rate (USGPM)	Air Flow (SCFM)	Cooling Capacity (Btuh)	EER	Heating Capacity (Btuh)	COP
007	1.8	260	7,700	18.4	6,900	3.9
009	2.4	320	10,100	18.3	9,100	3.8
012	3.0	425	14,200	18.1	12,900	3.6
018	4.8	640	22,900	20.2	18,800	3.9
024	6.0	800	28,700	20.8	23,600	3.8
030	7.8	1000	33,600	20.0	29,100	3.8
036	9.0	1200	39,800	18.8	37,200	3.9
042	10.4	1400	45,800	19.1	42,300	3.9
048	12.0	1600	52,500	19.3	47,400	3.8
060	15.0	2000	66,400	19.8	59,000	4.0
070	17.5	2200	73,600	18.7	66,800	3.8

\*Ground Water capacities are rated at 59°F EWT Cooling, 50°F EWT Heating.

**PERFORMANCE DATA - AHRI/ISO 13256-1 GROUND LOOP CONDITIONS\***

Unit Model	Flow Rate (USGPM)	Air Flow (SCFM)	Cooling Capacity (Btuh)	EER	Heating Capacity (Btuh)	COP
007	1.8	260	7,100	14.6	5,500	3.4
009	2.4	320	9,300	14.5	6,900	3.3
012	3.0	425	13,000	14.3	10,200	3.1
018	4.8	640	20,600	15.7	13,900	3.4
024	6.0	800	26,400	16.1	17,400	3.3
030	7.8	1000	31,100	15.3	22,500	3.3
036	9.0	1200	37,500	14.8	28,600	3.3
042	10.4	1400	43,900	14.6	32,300	3.4
048	12.0	1600	49,800	15.0	37,800	3.3
060	15.0	2000	62,900	15.6	47,200	3.5
070	17.5	2200	70,100	14.7	52,400	3.3

\*Ground Loop capacities are rated at 77°F EFT Cooling, 32°F EFT Heating.

**NOTE:**

- 1) All Cooling capacities based upon 80.6°F DB, 66.2°F WB entering air temperature.
- 2) All Heating capacities based upon 68°F DB, 59°F WB entering air temperature.

*Johnson Controls maintains a continuous product improvement policy; therefore specifications are subject to change without notice.*



BY JOHNSON CONTROLS

**DESCRIPTION**

AHRI/ISO 13256-1 PERFORMANCE DATA  
R-410A  
RSH & RSV SERIES  
WATER SOURCE HEAT PUMP

Form SK145.16-PA12 (1209)

DATE:

December 2009

Unit Size	SUPPLY VOLTAGE	COMPRESSOR				BLOWER		MIN. CCT. AMPACITY	MAX FUSE / CCT. BKR. AMP
		QTY	@	RLA	LRA	HP	FLA		
007	208-230/1/60	1	@	3.0	14.0	0.10	0.8	4.55	15
009	208-230/1/60	1	@	3.7	22.0	0.10	0.8	5.43	15
012	208-230/1/60	1	@	4.7	25.0	0.10	0.8	6.68	15
	265/1/60	1	@	4.2	22.0	0.10	0.8	6.05	15
018	208-230/1/60	1	@	6.5	43.0	0.17	1.4	9.53	15
	265/1/60	1	@	5.8	46.0	0.17	0.8	8.05	15
024	208-230/1/60	1	@	7.4	43.0	0.25	1.5	10.75	15
	265/1/60	1	@	6.7	46.0	0.25	1.3	9.68	15
	208-230/3/60	1	@	5.9	63.0	0.25	1.3	8.68	15
030	208-230/1/60	1	@	9.9	54.0	0.33	2.6	14.98	20
	265/1/60	1	@	8.5	46.0	0.33	1.9	12.53	20
	208-230/3/60	1	@	6.9	63.0	0.33	2.6	11.23	15
	460/3/60	1	@	3.6	30.0	0.33	1.6	6.10	15
036	208-230/1/60	1	@	13.0	74.0	0.50	3.2	19.45	30
	265/1/60	1	@	10.6	66.0	0.50	2.2	15.45	25
	208-230/3/60	1	@	7.8	68.0	0.50	3.2	12.95	20
	460/3/60	1	@	3.7	34.0	0.50	2.5	7.13	15
042	208-230/1/60	1	@	19.9	109.0	0.50	3.2	28.08	45
	208-230/3/60	1	@	13.1	83.1	0.50	3.2	19.58	30
	460/3/60	1	@	6.1	41.0	0.50	2.5	10.13	15
	575/3/60	1	@	4.2	33.0	0.50	1.8	7.05	15
048	208-230/1/60	1	@	23.1	144.0	0.75	4.9	33.78	50
	208-230/3/60	1	@	16.0	91.0	0.75	4.9	24.90	40
	460/3/60	1	@	7.1	46.0	0.75	2.2	11.08	15
	575/3/60	1	@	5.6	37.0	0.75	1.8	8.80	15
060	208-230/1/60	1	@	26.3	134.0	1.00	5.1	37.98	60
	208-230/3/60	1	@	15.6	110.0	1.00	5.1	24.60	40
	460/3/60	1	@	7.8	52.0	1.00	3.2	12.95	20
	575/3/60	1	@	5.8	38.9	1.00	2.6	9.85	15
070	208-230/3/60	1	@	19.0	123.0	1.00	5.1	28.85	45
	460/3/60	1	@	9.7	62.0	1.00	3.2	15.33	25
	575/3/60	1	@	7.4	50.0	1.00	2.6	11.85	15

Johnson Controls maintains a continuous product improvement policy; therefore specifications are subject to change without notice.



## DESCRIPTION

ELECTRICAL DATA  
R-410A  
RSH & RSV SERIES  
WATER SOURCE HEAT PUMP

Form SK145.16-PA12 (1209)

DATE:

December 2009

Unit Size	Rated CFM	Min. CFM	Motor Speed	External Static Pressure (in w.g.)								
				0	0.1	0.2	0.3	0.4	0.5	0.6	0.7	0.8
007	260	182	Med	260	250	235	205	185	160	130	-	-
009	320	224	High	385	375	360	335	295	260	220	-	-
012	425	298	High	430	420	400	385	370	350	315	280	-
018	640	448	High	-	-	860	850	820	775	705	600	465
			Med	745	735	710	685	655	615	560	500	-
			Low	540	535	525	495	460	420	380	335	-
024	800	560	High	-	1060	1010	955	905	830	755	660	540
			Med	900	870	840	800	760	705	650	560	-
			Low	805	775	745	705	670	625	570	490	-
030	1000	700	High	-	1170	1120	1075	1020	965	900	835	760
			Med	1000	970	945	905	860	820	780	725	655
			Low	855	820	785	750	710	670	630	590	-
036	1200	850	High	-	-	1540	1490	1435	1365	1285	1210	1110
			Med	1295	1275	1255	1240	1205	1160	1115	1060	990
			Low	1190	1160	1145	1115	1085	1045	1000	940	850
042	1400	980	High	-	-	1710	1695	1675	1655	1610	1560	1505
			Med	1400	1380	1355	1335	1305	1270	1245	1210	1170
			Low	1165	1155	1140	1110	1080	1050	1010	965	930
048	1600	1230	High	-	-	-	-	2000	1955	1900	1845	1780
			Med	1755	1745	1720	1690	1660	1630	1600	1555	1500
			Low	1505	1490	1465	1435	1400	1365	1325	1280	1230
060	2000	1620	High	-	-	2560	2530	2490	2440	2370	2300	2220
			Med	-	2100	2085	2060	2035	2000	1960	1910	1870
			Low	1905	1885	1860	1835	1805	1770	1730	1680	1620
070	2200	1620	High	-	-	2560	2530	2490	2440	2370	2300	2220
			Med	-	2100	2085	2060	2035	2000	1960	1910	1870
			Low	1905	1885	1860	1835	1805	1770	1730	1680	1620

Units are shipped pre-wired for Medium speed.  
All airflow ratings are at lowest voltage rating of dual rating (ie. 208 volt)  
Airflow ratings include resistance of wet coil and clean air filters.

Johnson Controls maintains a continuous product improvement policy; therefore specifications are subject to change without notice.



BY JOHNSON CONTROLS

DESCRIPTION

FAN PERFORMANCE  
R-410A  
RSH & RSV SERIES  
WATER SOURCE HEAT PUMP

Form SK145.16-PA12 (1209)

DATE:

December 2009

GENERAL

All R-series models ship as factory-charged packages, complete with R-410A refrigerant. All units from ½ to 6 tons shall be tested and certified by AHRI / ISO 13256-1 and ETL listed for United States and Canada. AHRI / ISO and ETL labels shall be applied prior to leaving the factory. All units are test operated at the factory.

Horizontal (RSH) units are designed for suspended ceiling mounting. RSH models are shipped with 'straight-through' evaporator fan discharge as standard. Fan orientation is field convertible to side discharge without the need for additional parts or unit modifications.

Vertical (RSV) units are designed for free-standing floor mounting. Vertical units are furnished with an internal condensate trap.

All units are completely factory wired and pre-piped. Water supply, water outlet, and condensate drain connections are via flush-mounted female NPT pipe thread fittings (no back-up wrench required).

A factory-trained and employed service technician must be located within 50 miles of installation location.

CABINET

All cabinets are completely constructed of corrosion resistant galvanized steel. The RSH units are complete with integral hanger channels. The entire unit interior (both evaporator and condensing section) is insulated with 1/2" thick, 2 lb density acoustical insulation. Insulation shall meet NFPA 90, UL-181, and ASTM-C1071 standards, and have a flame spread of less than 25 and a smoke developed classification of less than 50 per ASTM E-84 and UL 723. All units provide service access to the reversing valve, thermal expansion valve, and compressor with the unit remaining in location. An integral 3/4" duct collar is provided on the blower discharge opening. The unit shall have an insulated panel separating the fan and compressor compartments for superior sound attenuation. Separate openings shall be provided for line voltage and low voltage wiring.

REFRIGERATION CIRCUITS

All models shall have a sealed refrigerant circuit, utilizing high efficiency rotary, hermetic reciprocating or scroll compressors. Compressors are mounted with rubber isolators on acoustically tuned bases to minimize vibration transmission and enhance sound performance.

Internal overload protection is provided. External high pressure and low pressure cutout switches are included in each compressor control circuit. High and low pressure switches shall have flare (threaded) connections and quick connect electrical terminals, enabling easy replacement and service. Each refrigeration circuit includes an adjustable bi-flow thermal expansion valve (with external equalizer), bi-flow liquid line filter drier, and service gauge ports. The reversing valve is a pilot operated, sliding piston type with a replaceable magnetic solenoid coil.

The refrigerant-to-air heat transfer coils are constructed of internally enhanced copper tubes mechanically bonded to enhanced aluminum plate fins. The evaporator coil is employed in a draw-through configuration. Large evaporator coil face area minimizes potential water blow-off. A fully-insulated, corrosion resistant condensate sloped drain pan with condensate overflow switch is provided as standard.

- Optional anti-corrosion protective evaporator coil coating.
- Optional stainless steel drain pan.

The coaxial refrigerant-to-water heat exchangers feature a convoluted inner tube design for high heat transfer efficiency. Standard models feature a copper inner tube surrounded by a steel outer tube, and carry a 400 psig water side working pressure rating. Units shall be capable of operation with an entering fluid temperature range of 20°F to 110°F.

- Optional cupro-nickel condenser water coil.
- Optional condenser insulation package for low-water temperature, geothermal applications.

INDOOR FAN

Forward curved, double inlet and double width, direct-drive centrifugal blowers are used for air movement. Large diameter wheels are employed to provide required airflow performance at minimum sound levels. Blower wheels are fabricated of galvanized steel. Fan motors are PSC type, with minimum three speeds. The PSC motors feature permanently lubricated bearings and internal thermal overload protection

*Johnson Controls maintains a continuous product improvement policy; therefore specifications are subject to change without notice.*



BY JOHNSON CONTROLS

DESCRIPTION

MECHANICAL SPECIFICATION, 1 of 2  
R-410A  
RSH & RSV SERIES  
WATER SOURCE HEAT PUMP

Form SK145.16-PA12 (1209)

DATE:

December 2009

ELECTRICAL / CONTROLS

All units are completely factory wired with all necessary operating controls. A 24 volt control circuit, with oversized transformer, is provided for field connection. The reversing valve solenoid coil shall be energized in cooling mode only.

Unit shall have a microprocessor-based control system with the following:

- a. Unit shall operate with conventional thermostat designs.
- b. Unit shall incorporate a lockout circuit which provides reset capability at the space thermostat, base unit, or by interrupting service power, should any of the following standard safety devices trip and shut off the compressor.
  - c. Loss-of-charge/Low-pressure switch
  - d. High-pressure switch
  - e. Control board shall monitor each refrigerant safety switch independently.
  - f. Low water temperature protection
  - g. Condensate overflow protection
  - h. Low voltage (brown-out) protection
  - i. Anti-short cycle timer (ASCT)
  - j. Random start
- k. Should the high-pressure or low-pressure safeties open three times within two hours of operation (1 hour for low-pressure safety), then lockout requiring manual reset will occur.
- l. Should the low water temperature or condensate overflow safeties trip 3 times sequentially, then lockout requiring manual reset will occur.
- m. The low-pressure switch shall not be monitored during the initial 30 seconds of a cooling system's operation to prevent nuisance trips.
- n. Unit shall have capability to defeat time delays for servicing.
- o. Unit control board shall have on-board diagnostics and fault code display.
- p. Control board shall retain last 5 fault codes in non volatile memory which will not be lost in the event of a power loss.
- q. Unit shall have an automated sequence used after installation that quickly tests cooling and heating modes.

FILTERS

All models are shipped with 1-inch thick throwaway filters, factory installed. Filters are accessible from either side of unit. Factory-installed filter rack on horizontal units shall be adjustable from 1" to 2" without any additional parts or hardware.

FIELD INSTALLED ACCESSORIES

The following options are available field installation:

- Hose Kits (available options)
  - Automatic Flow Control Valve
  - 2 stainless steel braided flexible hoses (18"–36" lengths)
  - 2 manual isolation ball valves
  - High-flow "Y" strainer w/ blow down valve
  - Motorized water valve
- Electronic Thermostats
  - Programmable (7-day), 1 Ht / 1 Cl, back-lit display. The thermostat shall be supplied with an occupancy sensing cover (or be capable of being retrofitted on site for future occupancy sensing).
  - Non-programmable, 1 Ht / 1 Cl, back-lit display. The thermostat shall be supplied with an occupancy sensing cover (or be capable of being retrofitted on site for future occupancy sensing).
- 2" Filter Rack w/ Duct Collar
  - Fully sealed filter with side access
  - Ducted return air connection

*Johnson Controls maintains a continuous product improvement policy; therefore specifications are subject to change without notice.*



BY JOHNSON CONTROLS

DESCRIPTION

MECHANICAL SPECIFICATION, 2 of 2  
R-410A  
RSH & RSV SERIES  
WATER SOURCE HEAT PUMP

Form SK145.16-PA12 (1209)

DATE:

December 2009

### LEFT HAND RETURN

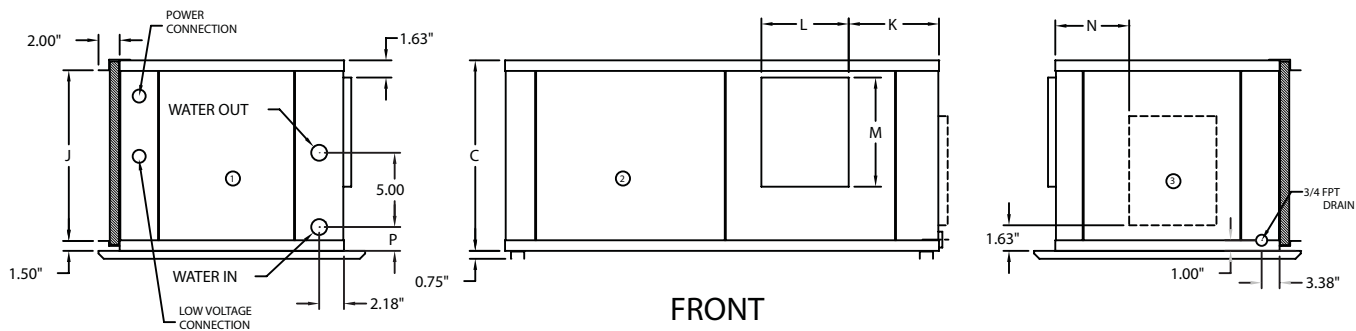
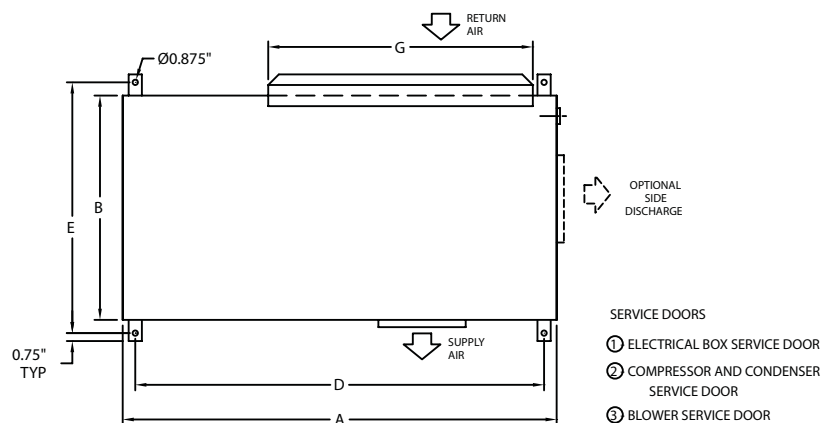

Model	A	B	C	D	E	RETURN AIR		K	SUPPLY AIR		N	P
						G	J		L	M		
RSH007	34.00	19.00	13.00	31.75	21.50	16.50	10.50	6.75	7.25	6.00	6.07	2.50
RSH009	34.00	19.00	13.00	31.75	21.50	16.50	10.50	6.75	7.25	6.00	6.07	2.50
RSH012	34.00	19.00	13.00	31.75	21.50	18.50	10.50	6.75	7.25	6.00	6.07	2.50
RSH018	40.00	21.00	19.00	37.75	23.50	23.00	16.50	6.50	9.19	10.31	3.75	2.80
RSH024	44.00	21.00	19.00	41.75	23.50	24.50	16.50	6.50	9.19	10.31	4.81	2.80
RSH030	44.00	21.00	19.00	41.75	23.50	24.50	16.50	6.50	9.69	11.38	4.81	2.80
RSH036	48.00	22.00	21.00	45.75	24.50	27.50	18.50	6.50	9.69	11.38	5.88	2.80
RSH042	52.00	26.00	21.00	49.75	28.50	35.50	18.50	6.50	10.50	13.63	5.88	2.80
RSH048	52.00	26.00	21.00	49.75	28.50	35.50	18.50	6.50	10.50	13.63	5.13	2.80
RSH060	56.00	26.00	23.00	53.75	28.50	43.50	20.50	6.00	13.12	13.63	5.13	3.06
RSH070	56.00	26.00	23.00	53.75	28.50	43.50	20.50	6.00	13.12	13.63	5.13	3.06

ALL DIMENSIONS IN INCHES

Johnson Controls maintains a continuous product improvement policy; therefore specifications are subject to change without notice.



DESCRIPTION

DIMENSIONAL DATA  
R-410A  
RSH SERIES – LEFT HAND RETURN  
HORIZONTAL WATER SOURCE HEAT PUMP

Form SK145.16-PA12 (1209)

DATE:

December 2009

**RIGHT HAND RETURN**

- SERVICE DOORS
- ① ELECTRICAL BOX SERVICE DOOR
  - ② COMPRESSOR AND CONDENSER SERVICE DOOR
  - ③ BLOWER SERVICE DOOR

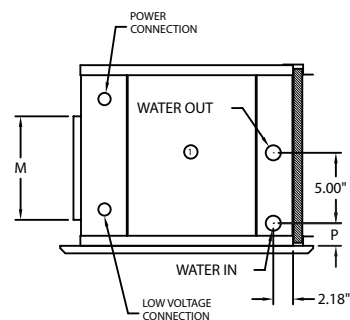
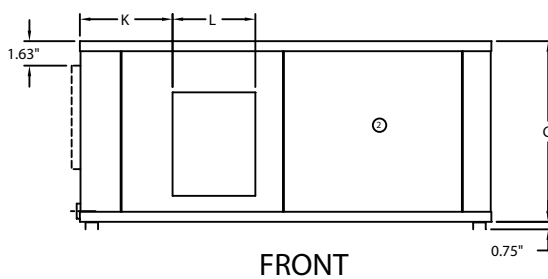
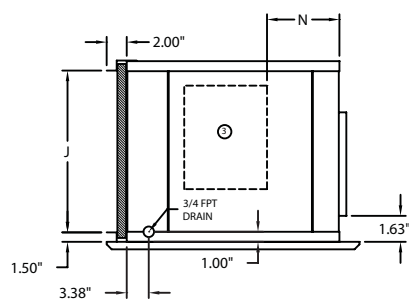
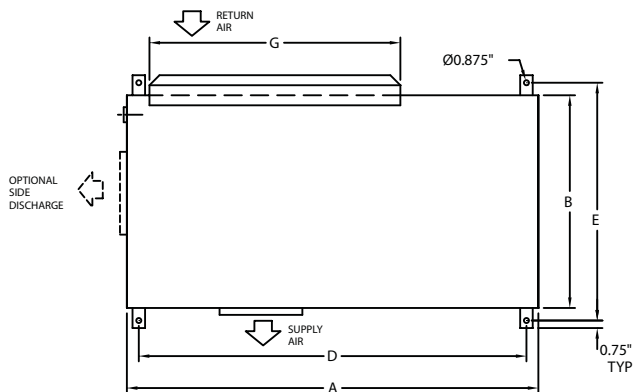

Model	A	B	C	D	E	RETURN AIR		K	SUPPLY AIR		N	P
						G	J		L	M		
RSH007	34.00	19.00	13.00	31.75	21.50	16.50	10.50	6.75	7.25	6.00	6.07	2.50
RSH009	34.00	19.00	13.00	31.75	21.50	16.50	10.50	6.75	7.25	6.00	6.07	2.50
RSH012	34.00	19.00	13.00	31.75	21.50	18.50	10.50	6.75	7.25	6.00	6.07	2.50
RSH018	40.00	21.00	19.00	37.75	23.50	23.00	16.50	6.50	9.19	10.31	3.75	2.80
RSH024	44.00	21.00	19.00	41.75	23.50	24.50	16.50	6.50	9.19	10.31	4.81	2.80
RSH030	44.00	21.00	19.00	41.75	23.50	24.50	16.50	6.50	9.69	11.38	4.81	2.80
RSH036	48.00	22.00	21.00	45.75	24.50	27.50	18.50	6.50	9.69	11.38	5.88	2.80
RSH042	52.00	26.00	21.00	49.75	28.50	35.50	18.50	6.50	10.50	13.63	5.88	2.80
RSH048	52.00	26.00	21.00	49.75	28.50	35.50	18.50	6.50	10.50	13.63	5.13	2.80
RSH060	56.00	26.00	23.00	53.75	28.50	43.50	20.50	6.00	13.12	13.63	5.13	3.06
RSH070	56.00	26.00	23.00	53.75	28.50	43.50	20.50	6.00	13.12	13.63	5.13	3.06

ALL DIMENSIONS IN INCHES

Johnson Controls maintains a continuous product improvement policy; therefore specifications are subject to change without notice.



DESCRIPTION

DIMENSIONAL DATA  
R-410A  
RSH SERIES – RIGHT HAND RETURN  
HORIZONTAL WATER SOURCE HEAT PUMP

Form SK145.16-PA12 (1209)

DATE:

December 2009

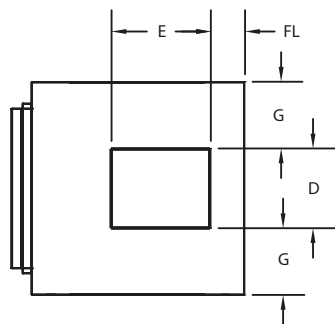

LEFT HAND RETURN

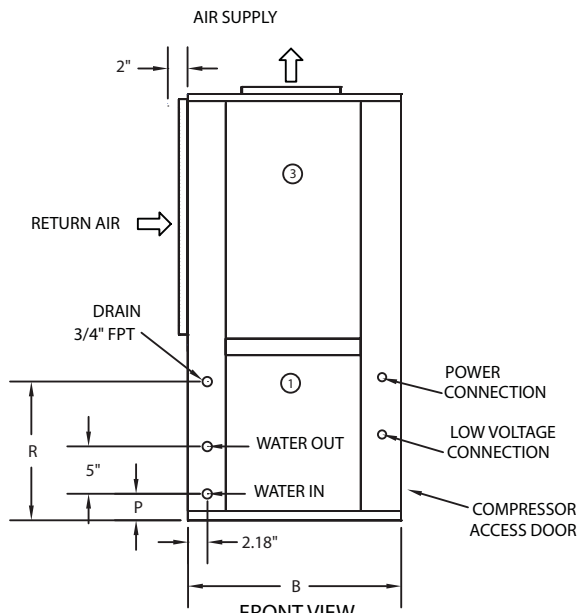

FRONT VIEW  
LEFT HAND RETURN

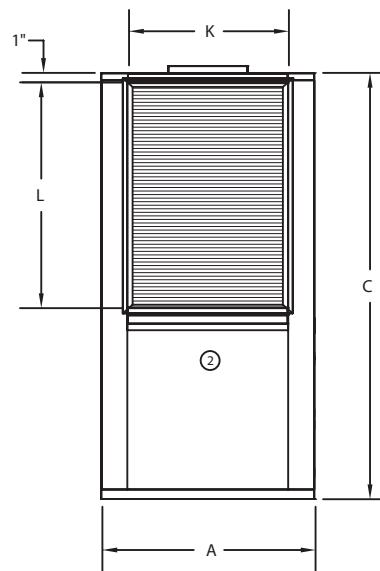

AIR COIL SIDE

- SERVICE DOORS
- ① ELECTRICAL BOX SERVICE DOOR
  - ② CONDENSER SERVICE DOOR (COMPRESSOR ACCESS OPPOSITE SIDE)
  - ③ BLOWER SERVICE DOOR

Model	A	B	C	SUPPLY AIR		FL	FR	G	RETURN AIR		P	R
				D	E				K	L		
RSV007	21.50	21.50	31.50	7.25	6.00	2.00	8.56	7.13	20.00	10.50	2.50	16.25
RSV009	21.50	21.50	31.50	7.25	6.00	2.00	8.56	7.13	20.00	10.50	2.50	16.25
RSV012	21.50	21.50	31.50	7.25	6.00	2.00	8.56	7.13	20.00	10.50	2.50	16.12
RSV018	25.50	23.00	40.00	9.19	10.31	2.00	6.00	8.16	25.00	16.50	2.75	18.56
RSV024	25.50	23.00	40.00	9.19	10.31	2.00	6.00	8.16	25.00	18.50	2.75	17.12
RSV030	25.50	23.00	40.00	9.69	11.38	2.00	5.00	7.91	25.00	18.50	2.75	17.12
RSV036	25.50	23.00	44.00	9.69	11.38	2.00	5.00	7.91	25.00	22.50	2.75	17.00
RSV042	28.00	25.50	46.00	10.50	13.63	2.00	5.00	8.75	23.00	26.00	2.75	15.25
RSV048	28.00	25.50	46.00	10.50	13.63	2.00	5.00	8.75	23.00	26.00	2.75	15.25
RSV060	32.50	27.50	50.00	13.12	13.63	3.00	6.00	9.69	28.00	30.00	3.06	15.00
RSV070	32.50	27.50	50.00	13.12	13.63	3.00	6.00	9.69	28.00	30.00	3.06	15.00

ALL DIMENSIONS IN INCHES

Johnson Controls maintains a continuous product improvement policy; therefore specifications are subject to change without notice.



BY JOHNSON CONTROLS

DESCRIPTION

DIMENSIONAL DATA  
R-410A

RSV SERIES – LEFT HAND RETURN  
VERTICAL WATER SOURCE HEAT PUMP

Form SK145.16-PA12 (1209)

DATE:

December 2009

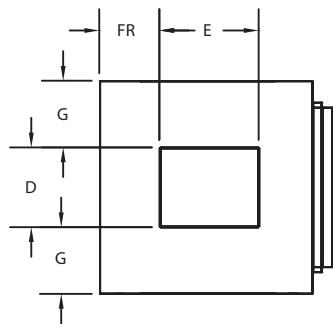

RIGHT HAND RETURN

AIR SUPPLY

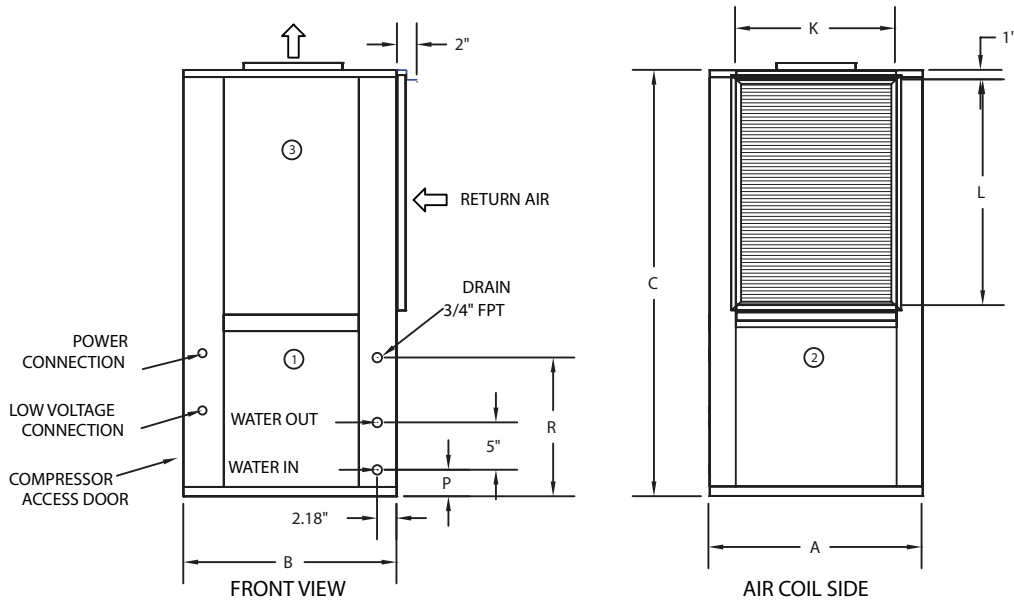

FRONT VIEW  
RIGHT HAND RETURN

AIR COIL SIDE

- SERVICE DOORS  
 ① ELECTRICAL BOX SERVICE DOOR  
 ② CONDENSER SERVICE DOOR (COMPRESSOR ACCESS OPPOSITE SIDE)  
 ③ BLOWER SERVICE DOOR

Model	A	B	C	SUPPLY AIR		FL	FR	G	RETURN AIR		P	R
				D	E				K	L		
RSV007	21.50	21.50	31.50	7.25	6.00	2.00	8.56	7.13	20.00	10.50	2.50	16.25
RSV009	21.50	21.50	31.50	7.25	6.00	2.00	8.56	7.13	20.00	10.50	2.50	16.25
RSV012	21.50	21.50	31.50	7.25	6.00	2.00	8.56	7.13	20.00	10.50	2.50	16.12
RSV018	25.50	23.00	40.00	9.19	10.31	2.00	6.00	8.16	25.00	16.50	2.75	18.56
RSV024	25.50	23.00	40.00	9.19	10.31	2.00	6.00	8.16	25.00	18.50	2.75	17.12
RSV030	25.50	23.00	40.00	9.69	11.38	2.00	5.00	7.91	25.00	18.50	2.75	17.12
RSV036	25.50	23.00	44.00	9.69	11.38	2.00	5.00	7.91	25.00	22.50	2.75	17.00
RSV042	28.00	25.50	46.00	10.50	13.63	2.00	5.00	8.75	23.00	26.00	2.75	15.25
RSV048	28.00	25.50	46.00	10.50	13.63	2.00	5.00	8.75	23.00	26.00	2.75	15.25
RSV060	32.50	27.50	50.00	13.12	13.63	3.00	6.00	9.69	28.00	30.00	3.06	15.00
RSV070	32.50	27.50	50.00	13.12	13.63	3.00	6.00	9.69	28.00	30.00	3.06	15.00

ALL DIMENSIONS IN INCHES

Johnson Controls maintains a continuous product improvement policy; therefore specifications are subject to change without notice.



BY JOHNSON CONTROLS

DESCRIPTION

DIMENSIONAL DATA  
R-410A

RSV SERIES – RIGHT HAND RETURN  
VERTICAL WATER SOURCE HEAT PUMP

Form SK145.16-PA12 (1209)

DATE:

December 2009

# RSH/RSV SERIES; 208-230V/1Ph/60Hz 265V/1Ph/60Hz

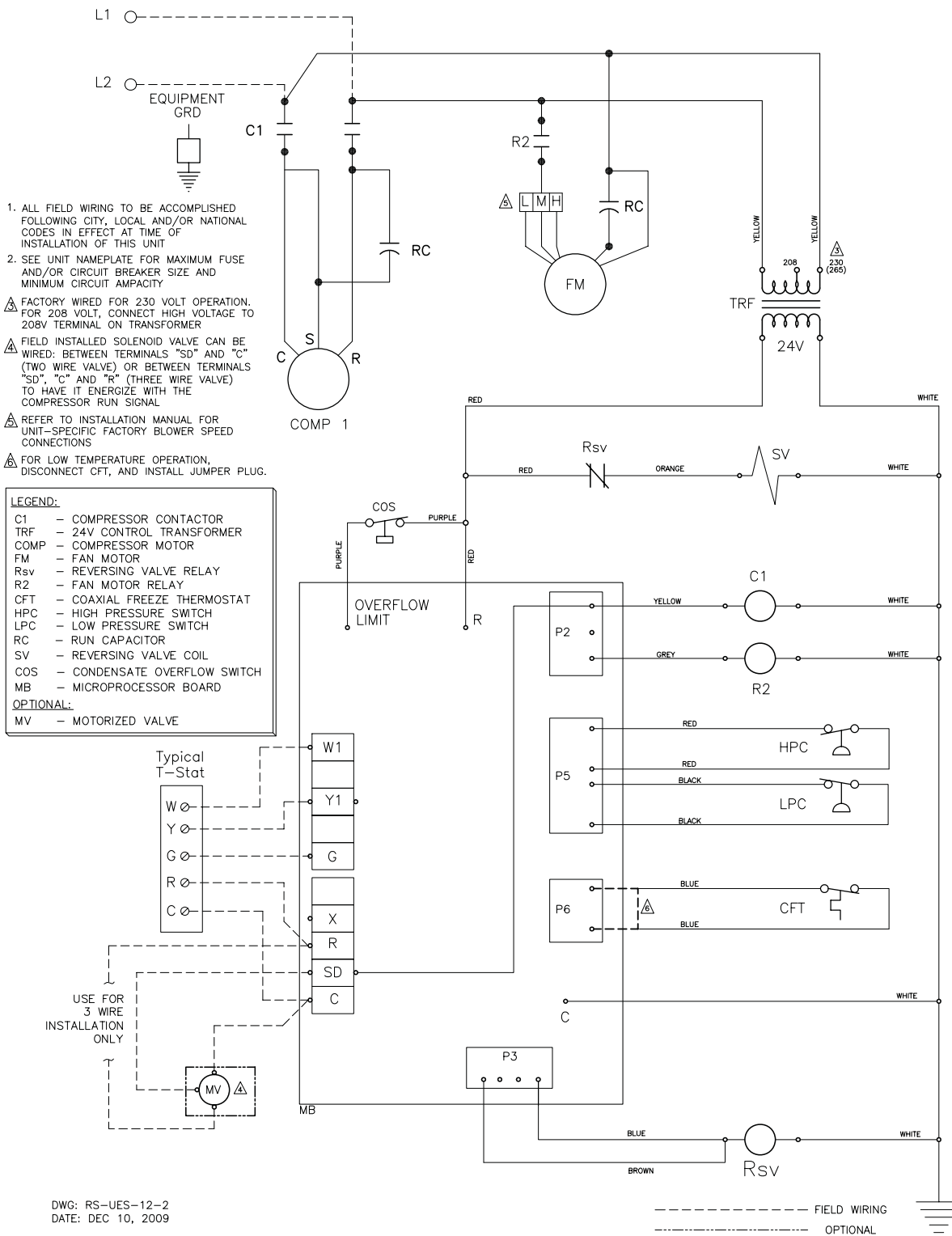

Johnson Controls maintains a continuous product improvement policy; therefore specifications are subject to change without notice.



DESCRIPTION

WIRING DIAGRAM  
R-410A  
RSH & RSV SERIES  
WATER SOURCE HEAT PUMP

Form SK145.16-PA12 (1209)

DATE:  
December 2009

# RSH/RSV SERIES; 208-230V/3Ph/60Hz

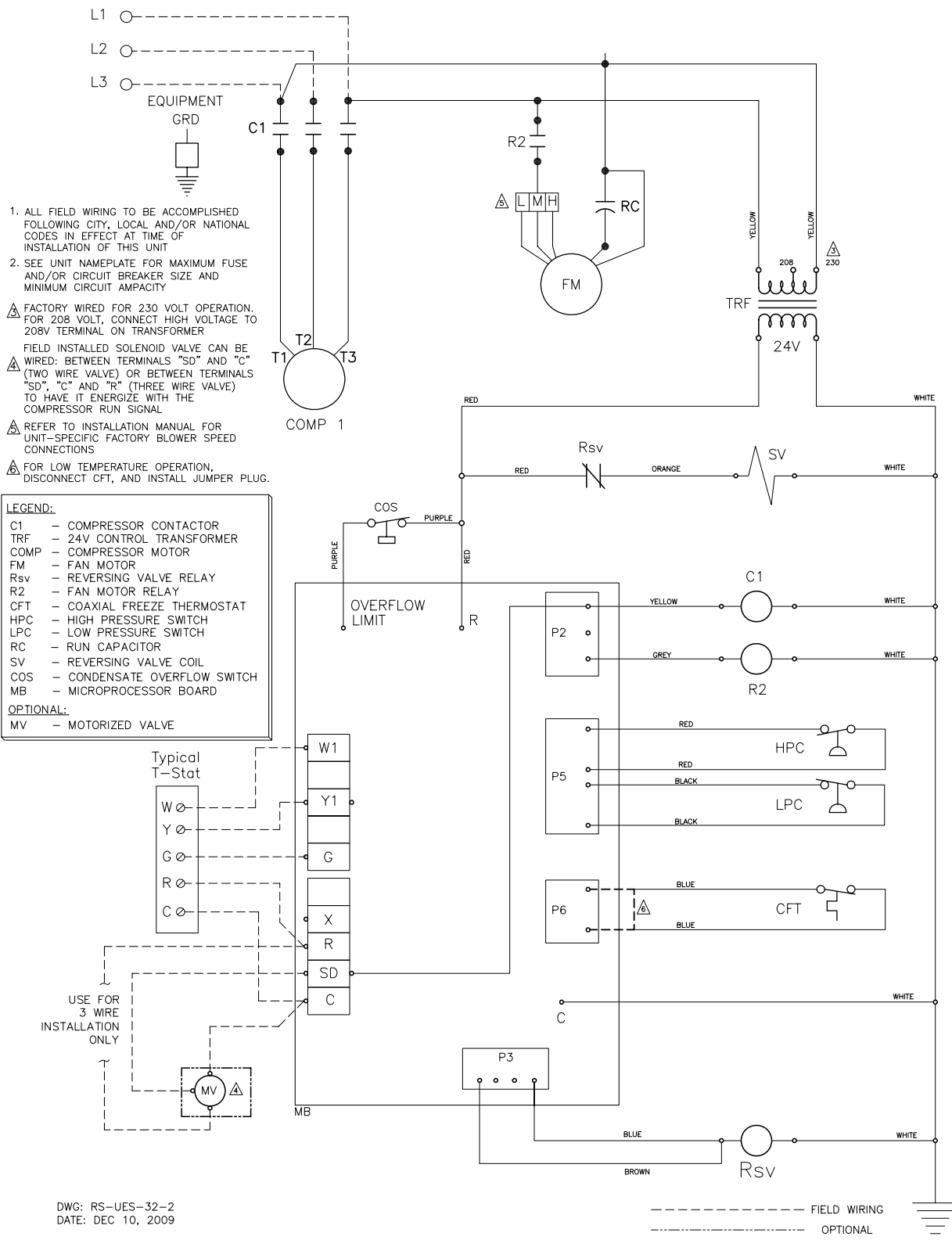

Johnson Controls maintains a continuous product improvement policy; therefore specifications are subject to change without notice.



BY JOHNSON CONTROLS

DESCRIPTION

WIRING DIAGRAM  
R-410A  
RSH & RSV SERIES  
WATER SOURCE HEAT PUMP

Form SK145.16-PA12 (1209)

DATE: December 2009

# RSH/RSV SERIES; 460-575V/3Ph/60Hz

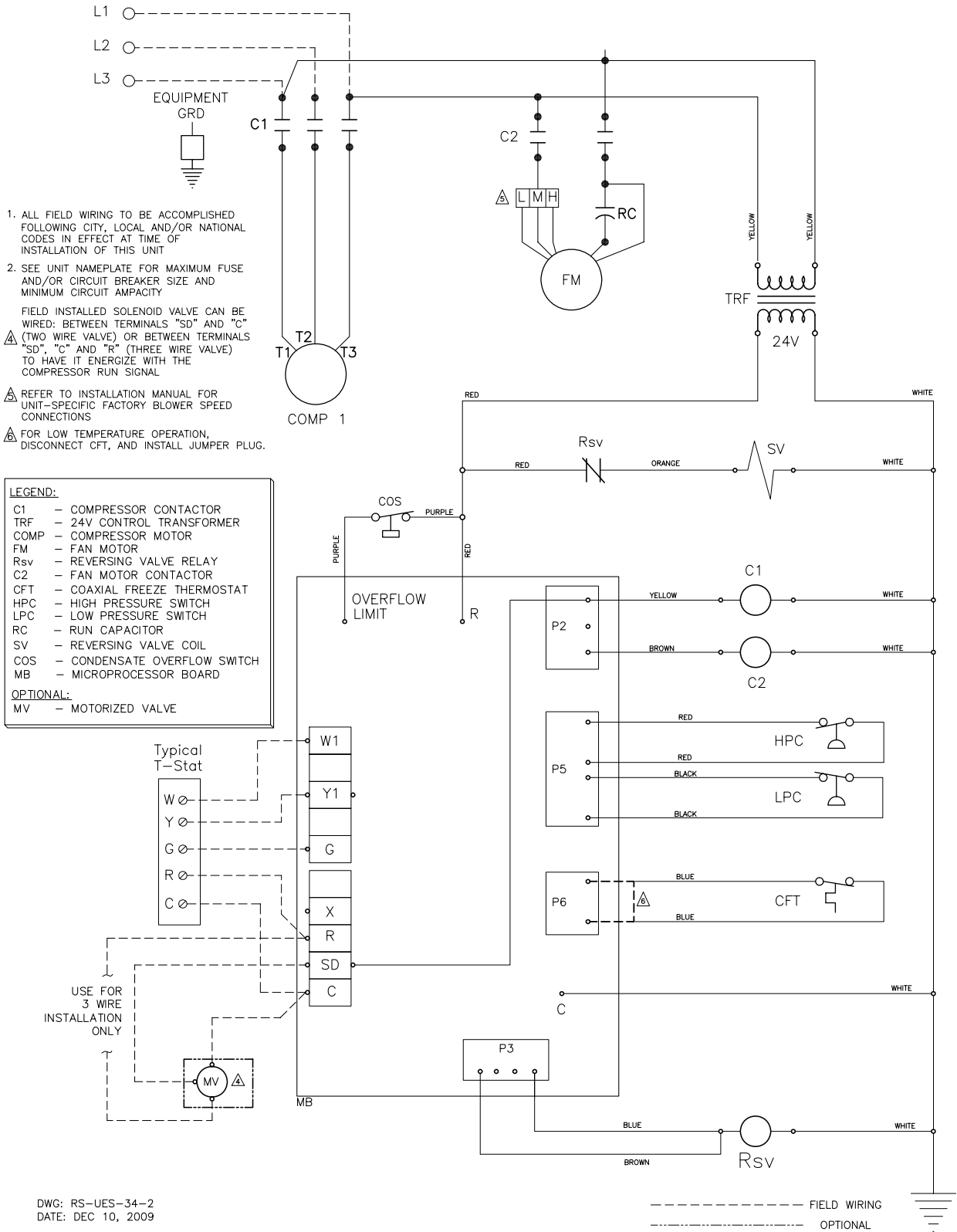

DWG: RS-UES-34-2  
DATE: DEC 10, 2009

Johnson Controls maintains a continuous product improvement policy; therefore specifications are subject to change without notice.



DESCRIPTION

WIRING DIAGRAM  
R-410A  
RSH & RSV SERIES  
WATER SOURCE HEAT PUMP

Form SK145.16-PA12 (1209)

DATE: December 2009