

PROJECT:

TAG:

NOMINAL COOLING (Ton):	3
Total Cooling Capacity [Btuh]:	35,900
Sensible Cooling Capacity [Btuh]:	27,500
Energy Efficiency Ratio (EER):	9.5*

Total Heating Capacity [Btuh]:	39,600
COP:	3.2*

Indoor Blower, Direct Drive:	CENTRIFUGAL
Diameter x Width [in]:	9 x 7
Design CFM:	1150
Motor HP / Speeds:	0.33 / 3

Indoor Coil:	Copper tubes, Aluminum Fins
Face Area (sq. ft.)	2.88
Rows / FPI:	4 / 11

Compressor No./Type:	1/Scroll
Refrigerant:	R-410A
Factory Charge [oz.]:	91

Outdoor Blower, Direct Drive:	CENTRIFUGAL
Diameter x Width [in]:	11 x 7T
Design CFM:	1650
Motor HP / Speeds:	0.50 / 1

Outdoor Coil:	Copper tubes, Aluminum Fins
Face Area (sq. ft.)	4.48
Rows / FPI:	4 / 16

Filter Size:	25x20x1
Shipping Weight [lbs.]:	345

*Tested in Accordance with ARI Standard 390-2003. Cooling rating conditions are 80°F DB/67°F WB EAT-Indoor Coil, 95°F EAT-Outdoor Coil, Standard Design CFM's. Heating rating conditions are 47°F DB/43°F WB EAT-Outdoor Coil, 70°F EAT-Indoor Coil, Standard Design CFM's.

Electric Heater Data

Nominal Output @ 240V [kW]	Output @ 208V [kW]	Capacity @ 240V [Btuh]	Capacity @ 208V [Btuh]	Total Heating AMPS @240V	Total Heating AMPS @208V
6	4.50	20,500	15,350	25.0	21.6
8	6.00	27,300	20,500	33.3	28.8
10	7.50	34,100	25,600	41.7	36.1

INDOOR BLOWER CFM - VPC & VPP MODELS

Model #	Motor Speed	EXTERNAL STATIC PRESSURE							
		0.05	0.10	0.15	0.20	0.25	0.30	0.35	0.40
VPC/VPP**36	HIGH	1320	1300	1275	1250	1220	1190	1160	1125
	MED	1140	1130	1115	1100	1080	1060	1035	1010
	LOW	-	940	935	930	925	920	905	885

ELECTRICAL DATA - VERTICAL PTAC WITH ELECTRIC HEAT OPTION 208-230/1/60

MODEL #	COMPRESSOR			INDOOR FAN		OUTDOOR FAN		HEATER KW			MCA			MAX FUSE / CCT. BKR. AMP		
	QTY	RLA	LRA	HP	FLA	HP	FLA	208V	230V	240V	208V	230V	240V	208V	230V	240V
VPP0636	1	@ 16.7	79.0	0.33	2.60	0.50	3.60	4.51	5.51	6.00	30.33	33.20	34.50	40	40	40
VPP0836	1	@ 16.7	79.0	0.33	2.60	0.50	3.60	6.01	7.35	8.00	39.36	43.18	44.92	40	45	45
VPP1036	1	@ 16.7	79.0	0.33	2.60	0.50	3.60	7.51	9.18	10.00	48.39	53.16	55.33	50	60	60

SKYMARK maintains a continuous product improvement policy, therefore specifications are subject to change without notice



SKYMARK INTERNATIONAL INC.
AJAX, ONTARIO, CANADA

DESCRIPTION:

VPP**3612B
VERTICAL PTAC UNIT
AIR TO AIR HEAT PUMP with ELECTRIC HEAT

REF No.:

VPP36-USD-01

DATE:

Jan 19, 2007

GENERAL

All models are shipped as a factory tested through-the-wall packaged HVAC system. The unit installs in a closet having an exterior wall. VP units are designed for Wall Sleeve mounting. The Wall Sleeve is permanently built into the building wall at the rough-in stage. All units are completely factory wired and pre-piped. Condensate drain connection is via a female pipe thread fitting located on the bottom of the wall sleeve.

CABINET

All cabinets are completely constructed of heavy gauge, corrosion resistant, galvanized steel. The entire unit interior (both evaporator and condensing section) is insulated with 1/2" thick, high-density insulation.

All models allow service access to the reversing valve (VPP units only), electric heater, condenser blower/motor, and compressor with the unit remaining in location. An integral duct collar is provided on the indoor blower discharge opening.

REFRIGERATION CIRCUIT

All models utilize high efficiency rotary or scroll compressors. Each refrigeration circuit is thoroughly evacuated, and fully charged with R-410A refrigerant before shipment. Internal motor overload protection is provided. Compressors are mounted on rubber isolators to minimize vibration transmission.

The refrigeration circuit includes a bi-flow thermal expansion valve (with external equalizer), bi-flow liquid line filter drier, a high refrigerant pressure safety switch (manual-reset), and service gauge ports.

The reversing valve (VPP units only) is a pilot operated, sliding piston type with a replaceable magnetic solenoid coil.

The indoor and outdoor coils are constructed of internally enhanced copper tubes mechanically bonded to enhanced aluminum plate fins. The coils are employed in a draw-through configuration.

INDOOR / OUTDOOR FAN

Forward curved, double inlet and double width, direct-drive centrifugal blowers are used for air movement. Large diameter wheels are employed to provide required airflow performance at minimum noise levels. Fan motors are PSC types, with minimum three speeds on indoor fan and one speed on outdoor fan. The PSC motors feature permanently lubricated bearings and internal thermal overload protection.

ELECTRICAL/CONTROLS

All units are completely factory wired with all necessary operating controls. A factory installed electrical disconnect is provided for service convenience and maintenance.

Units are designed to operate with conventional thermostat control interface. A solid state time delay relay provides both random-start, and compressor anti-short cycle protection standard in all units.

Both Cooling and Heat pump models feature an ambient out-door temperature sensor to lockout compressor operation below 40°F. Additionally, a low suction temperature thermostat is included in the compressor control circuit to prevent evaporator icing during cooling operation at lower out-door ambient temperatures.

The reversing valve solenoid coil is energized in cooling mode only (VPP units only).

An optional remote management relay allows the unit to be enabled or disabled from an external source.

FRESH AIR INTAKE

A mechanical fresh air intake, with adjustable damper, is provided to meet code requirements for fresh air introduction. This ventilation air minimizes infiltration by pressurization of the conditioned space.

FILTERS

All models are shipped with a 25x20x1-inch thick throwaway filter, factory installed. Filters are accessible from front of unit.

SKYMARK maintains a continuous product improvement policy, therefore specifications are subject to change without notice.



SKYMARK INTERNATIONAL INC.
AJAX, ONTARIO, CANADA

DESCRIPTION:

MECHANICAL SPECIFICATIONS
2-1/2 & 3 TON VERTICAL PTAC UNITS
with R-410A Refrigerant

REF No.:

VPTAC2-MES-03

DATE:

September 12, 2006

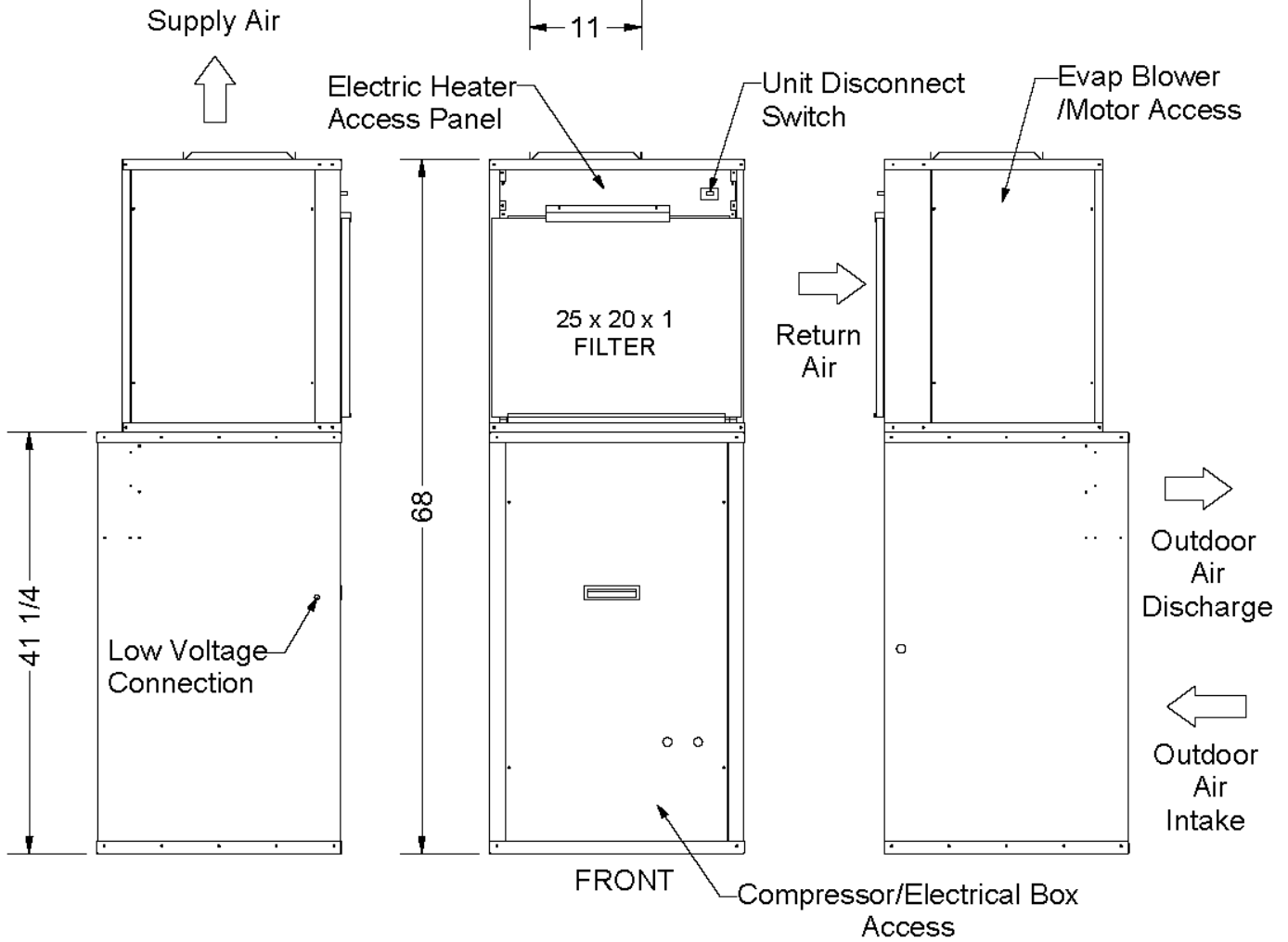
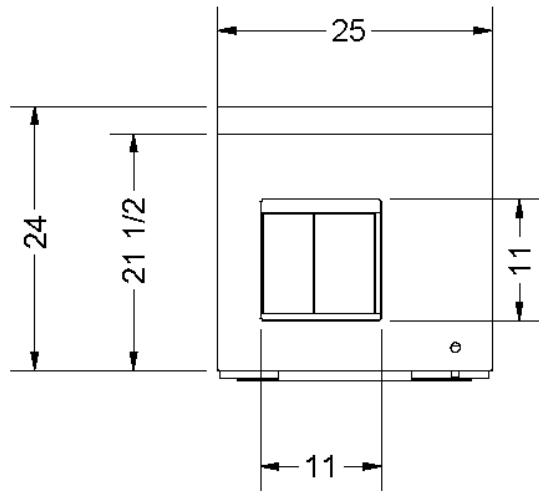

SKYMARK maintains a continuous product improvement policy, therefore specifications are subject to change without notice.



SKYMARK INTERNATIONAL INC.
AJAX, ONTARIO, CANADA

DESCRIPTION:

VPP/VPC 2-1/2 & 3 TON SERIES
VERTICAL AIR CONDITIONER/HEAT PUMP
DIMENSIONAL DATA

REF No.:

VPPC2-USS-03

DATE:

September 12, 2006

VERTICAL PTAC UNIT

2 1/2 & 3 TON ALL MODELS INSTALLATION DETAILS

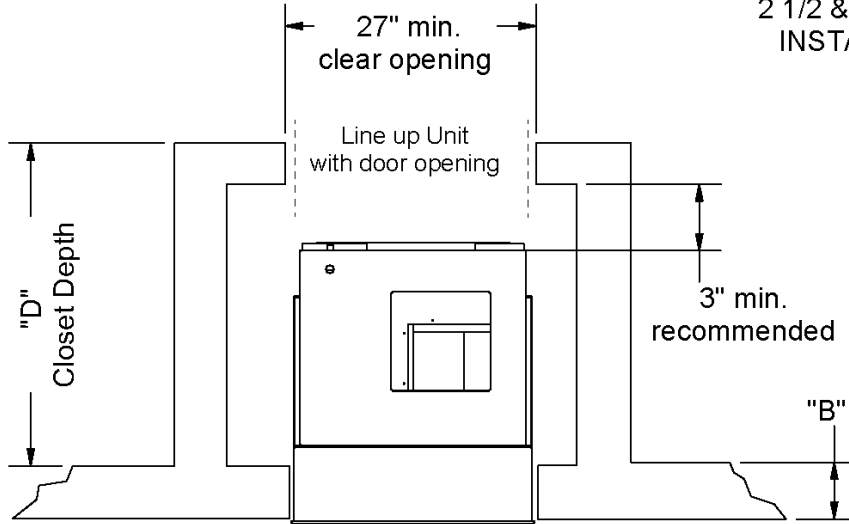

Outside Wall Thickness 5" - 8"
D = 33" - B

Outside Wall Thickness 8" - 12"
D = 37" - B

Outside Wall Thickness 12" - 15"
D = 40" - B

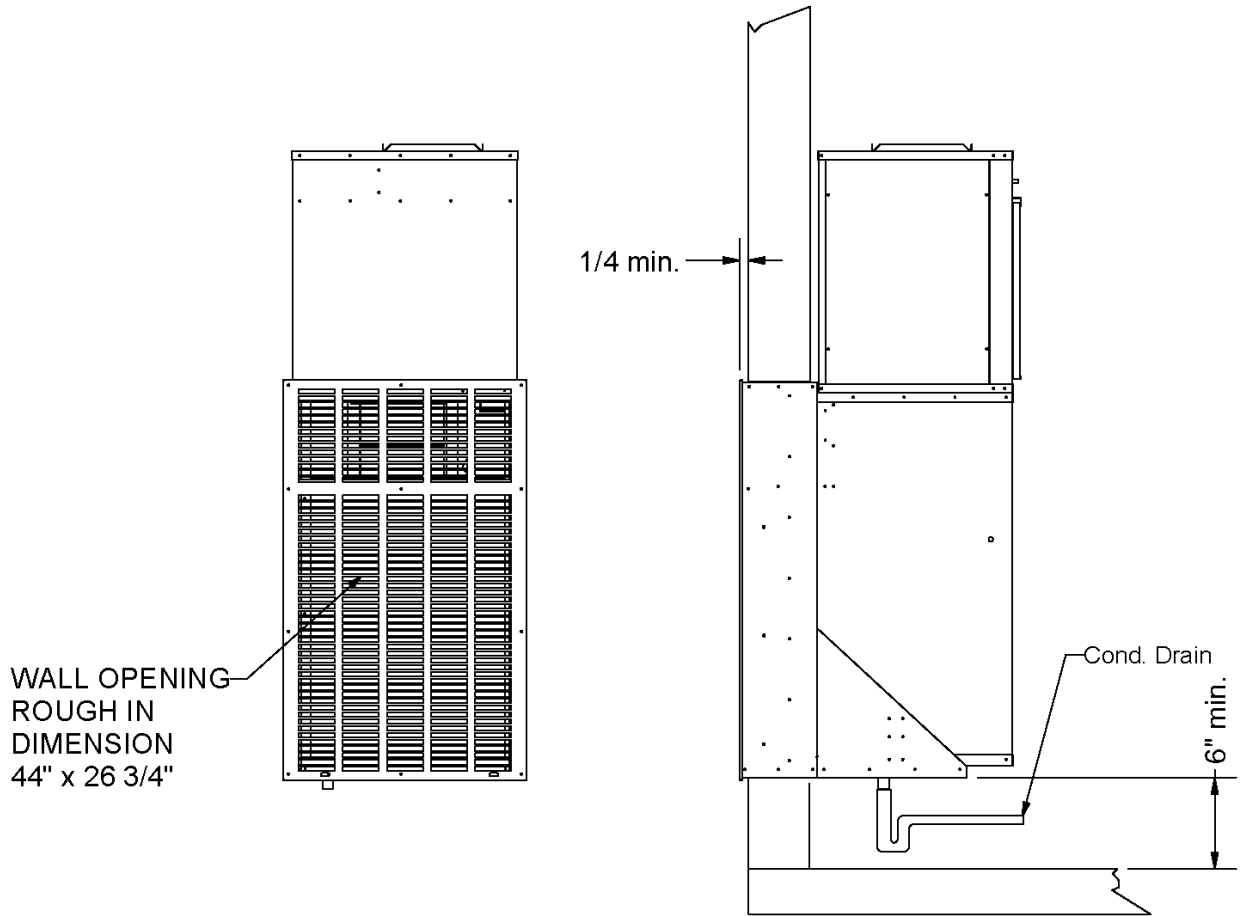

SKYMARK maintains a continuous product improvement policy, therefore specifications are subject to change without notice.



SKYMARK INTERNATIONAL INC.
AJAX, ONTARIO, CANADA

DESCRIPTION:

VPP/VPC/VPH 2-1/2 & 3 TON SERIES
INSTALLATION CLEARANCES &
SLEEVE MOUNTING DETAIL

REF No.:

VPTAC2-INS-03

DATE:

September 12, 2006